

FIXED DECK MONITOR



Knowsley SK Limited - Designer and Manufacturer of Fire Fighting Equipment & Systems

We know Fire. We know safety. We know you.





Established in 1896, Knowsley SK Ltd has an enviable reputation for manufacturing quality fire fighting equipment and systems for high-value asset protection that can be relied upon whenever danger strikes.

01 Product Overview

Fixed deck monitors provide a versatile fire fighting capability for many industrial and petrochemical scenarios such as:

Process plant storage tank farms, loading bays, marine wharves and jetties, offshore platforms and helidecks etc.

Features

- Single waterway
- Undivided water stream
- Low pressure loss
- Easy operation
- Lockable in horizontal and vertical position
- Unattended operation
- Robust construction
- Corrosion resistant materials
- Rotation - full 360 degrees
- Elevation - +90 degrees
- Depression - -90 degrees

The Knowsley range is of robust design, manufactured from corrosion resistant materials and can be locked in position enabling unattended operation and reduced risk to the fire fighter.

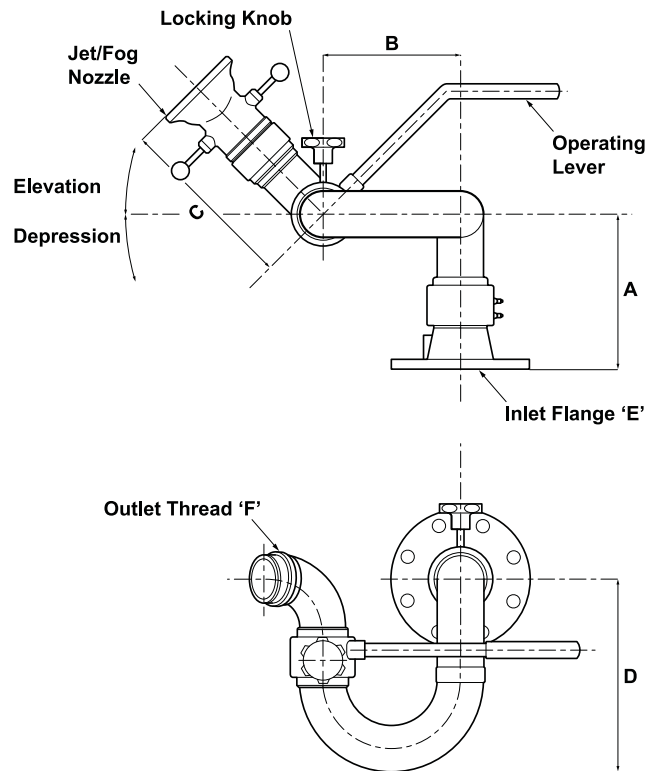

Figure 1. Fixed Deck Monitor

02 Overall Dimensions

Overall dimensions are shown in table 1. See Figure 1. for corresponding annotations.

Table 1. Overall Dimensions

MODEL No	SIZE	A	B	C	D	E	F	Weight
5146	3"	257	228	300	322	3"/OR 4"	2½" NSTM	30Kg
5119	4"	263	228	325	338	4"/OR 6"	4" NSTM	40Kg

03 Product Materials

The Fixed Deck Monitor is manufactured from the following corrosion resistant materials:

- Inlet Stand: Gunmetal CC492K-GS
- Upper and Lower Bend: Gunmetal CC492K-GS
- Operating Lever: Stainless Steel (with plastic hand grip)
- Ball bearings: Stainless Steel
- O Rings: Buna – N
- Grease Nipple: Stainless Steel

Standard Painting Cycle

Two coat enamel finish for aesthetic purpose and colour identification

Red to BS4800 04–E–53 (Other colours available)

Total 70 Microns DFT (min)



Knowsley SK Limited, Centrepoint, Marshall Stevens Way, Trafford Park, Manchester M17 1AE
Tel: +44(0)161 872 7511 Fax: +44(0)161 848 8508 Email: Sales@knowsleysk.co.uk Web: www.knowsleysk.com

Registered in England No. 1789152 VAT No:383475131



Our Century of experience, continuous product development and world-wide support network provides the confidence for clients to select Knowsley SK as their first choice for asset protection whatever, whenever and wherever the risk.



04 Product Details

The Knowsley fixed deck monitor provides an undivided stream of water with minimum flow restriction over a wide operating pressure range. This ensures impressive performance with high flow rates and low trajectories.

The monitor comprises essentially an inlet stand with lower and upper bend assemblies, and a threaded outlet enabling a variety of discharge nozzles to be utilised.

Swivel joints have twin bearing races to ensure smooth operation, and twin quading seals to prevent leaks. The flanged inlet enables locating the monitor on pipe-stands, hydrants, fire trucks, firemains or towers.

05 Performance Data

Fixed deck monitor Performance data is shown in Table 2.

Table 2. Performance Data

MODEL No	Max Capacity (LPM)	Operating Pressure Range	Elevation Degrees	Depression Degrees	Rotation Degrees
5146	3300	3.5–16 Bar	90	90	360
5119	5000	3.5–16 Bar	90	90	360

06 Spares Information

Please contact our dedicated spares department for the components listed below: spares@knowsleysk.co.uk

1. Grease Nipple
2. Quading Seal
3. Ball bearings
4. Locking Knob

07 Accessories Overview

The Knowsley fixed deck monitor can be fitted with a variety of discharge nozzles to suit different applications.

These include:—

Jet/Fog nozzles, Foam Branchpipes, self inducing foam nozzles and constant flow nozzles.

Our highly experienced engineers will select the correct nozzle for your application.

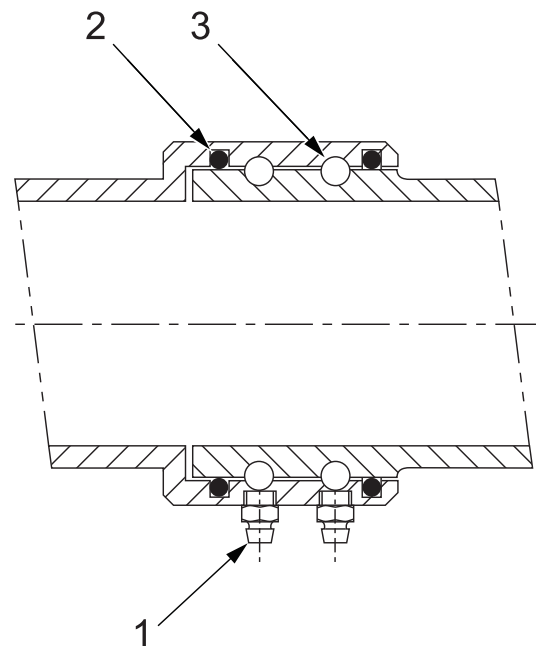

Figure 2. Section showing details of bearings



Knowsley SK Limited, Centrepoint, Marshall Stevens Way, Trafford Park, Manchester M17 1AE
Tel: +44(0)161 872 7511 Fax: +44(0)161 848 8508 Email: Sales@knowsleysk.co.uk Web: www.knowsleysk.com

Registered in England No. 1789152 VAT No:383475131

